

# RL-P270AJ

# Programmable Heavy Duty Shaft Encoder

## DESCRIPTION

The RL-P encoder converts shaft rotation into square wave output pulses to provide an accurate and reliable means of digitizing position, rate, or length of travel. The number of pulses per each revolution of the shaft and the output circuit type are selectable by setting configuration switches. The RL-P is intended to be shaft coupled using a flexible shaft coupling or other means to resolve shaft to shaft misalignment, or using a timing belt and sprocket.

## FEATURES



- Programmable Pulses/Revolution and Output Circuit
- ESD / Short Circuit / Reverse Voltage Protected
- Exclusive "Anti-jitter" Circuit for Conveyor Applications

\* CE marking requires Photocraft cable, and surge protection option if cable exceeds 100' (30m) or leaves the building.

## DIMENSIONS

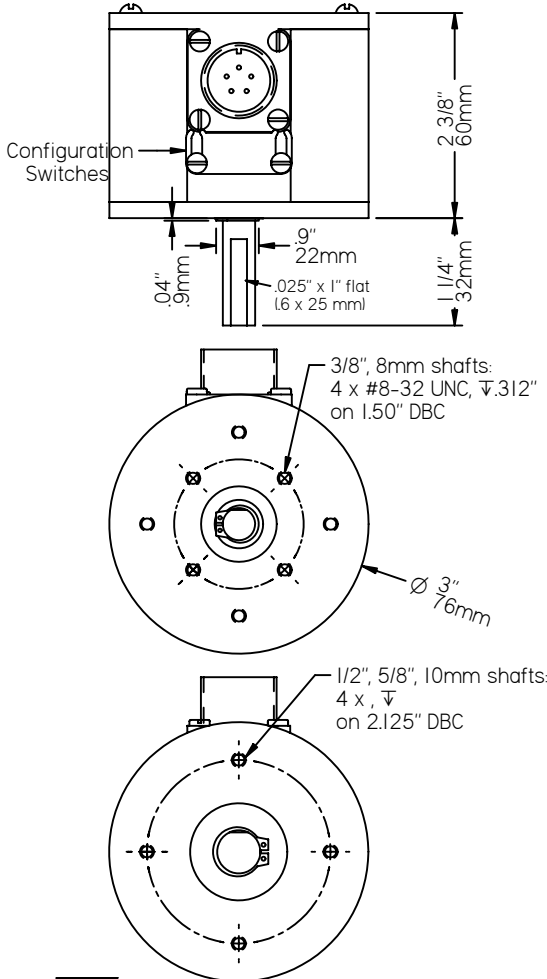

OVER 30 YEARS OF  
MATERIAL HANDLING AND  
INDUSTRIAL EXPERIENCE

602 E. North Street Elburn, IL 60119, USA  
630-365-7148 Fax: 630-365-7149  
www.photocraftencoders.com

## SPECIFICATIONS

### Mechanical

Weight: 16.8 oz (475 gm) without cable

#### Shaft Loading:

Shaft Diameter	Radial Lbs (kg)	Axial Lbs (kg)	Factor (BL)
3/8" / 8mm	40 (18.1)	30 (13.6)	32
1/2" / 10mm	45 (20.4)	35 (15.9)	37
5/8"	50 (22.7)	40 (18.1)	41

Bearing Life: BL x 1,000,000/rpm = hours

#### Materials:

- Case: 1/4" Aluminum, anodized
- Shaft: 303 Stainless steel
- Switch cover: ABS plastic

### Electrical Connections

Pin No.	Function	Wire Color
A	+vdc	Red
B	Common	Black
C	Output	White
D	no connection	—
E	no connection	—

### Configuration Switches

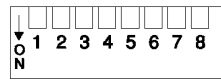

#### Output Circuit Selection

- 6 7 8
- Current sourcing (PNP)
  - Current sinking (NPN)
  - NPN open collector
  - Push-Pull output

#### Pulses per Revolution Selection

1	2	3	4	5	8	9	10	11	12	18	19	20	21	22
<input type="checkbox"/>	<input type="checkbox"/>	<input type="checkbox"/>	<input type="checkbox"/>	<input type="checkbox"/>	<input type="checkbox"/>	<input type="checkbox"/>	<input type="checkbox"/>	<input type="checkbox"/>	<input type="checkbox"/>	<input type="checkbox"/>	<input type="checkbox"/>	<input type="checkbox"/>	<input type="checkbox"/>	<input type="checkbox"/>
3	4	5	6	7	10	12	15	16	17	24	30	34	38	42
<input type="checkbox"/>	<input type="checkbox"/>	<input type="checkbox"/>	<input type="checkbox"/>	<input type="checkbox"/>	<input type="checkbox"/>	<input type="checkbox"/>	<input type="checkbox"/>	<input type="checkbox"/>	<input type="checkbox"/>	<input type="checkbox"/>	<input type="checkbox"/>	<input type="checkbox"/>	<input type="checkbox"/>	<input type="checkbox"/>
6	7	8	9	10	16	18	20	22	24	54	60	66	72	78
<input type="checkbox"/>	<input type="checkbox"/>	<input type="checkbox"/>	<input type="checkbox"/>	<input type="checkbox"/>	<input type="checkbox"/>	<input type="checkbox"/>	<input type="checkbox"/>	<input type="checkbox"/>	<input type="checkbox"/>	<input type="checkbox"/>	<input type="checkbox"/>	<input type="checkbox"/>	<input type="checkbox"/>	<input type="checkbox"/>

Switch definitions:  Up (off),  Down (on).

### Electrical

Supply Voltages (Vin): (specify when ordering)

- 5 ± 5% vdc
- 8 to 30 vdc

Supply Current: 50 ma max (no load)

Output Current (Io): 50ma max source/sink

Output Circuit: (see configuration switches)

- Current sinking NPN transistor with pull-up resistor\*
- Current sinking NPN open collector (30 vdc max)
- Current sourcing PNP with pull-down resistor\*
- Push/Pull output

\* Load Resistor value is 3.3K ohms

#### Output Protection:

- Short Circuit
- ESD to 8KV direct and 25KV air

Operating Temperature: -25° to +85° C

Maximum Operating Speed: 2,500 rpm

### Outputs

Pulses per Revolution: Selectable by setting switches 1 to 5 (see configuration switches)

Output Waveform: 50/50 squarewave

- Pulse On-Off Ratio: 50%±10%
- Pulse Interval Jitter: ±10%
- Pulse rise time: 2 µsec (max)
- Pulse fall time: 5 µsec (max)
- Voltage (high): Vin-2.5 vdc (min)
- Voltage (low): 1.5 vdc (max)

(600 rpm, Vin=24vdc, 10ma<Io<50ma, 25°C)

Anti-jitter: Increases the pulse hysteresis to 1/2 of a pulse width, eliminating the effects of mechanical vibration and the possible dither that results in false output pulses. For example a 10 pulse per revolution output would have 18° hysteresis (i.e. 360° ÷ 10 × 1/2).

## MODEL NUMBER

RL	P270AJ			
<b>Model Number</b>	<b>Program Name</b>	<b>Supply Voltage:</b> 5 = 5vdc, 8-30 = 8-30vdc	<b>Modification Number:</b> optional modification or special feature ID. Call or see our website.	<b>Accessories:</b> leave blank for no accessories. Call or see our website for more information.
Shaft Diameter: blank for 3/8", .5 = 1/2", .625 = 5/8", M8 = 8mm, M10 = 10mm, D = 3/8" double ended	Call or see our website for information about other available programs for this encoder model.			

Example: RL.5-P270AJ/8-30 - .5" shaft, P270AJ program, 8-30vdc