

DESCRIPTION

The RH-P encoder, also known as a Pulse Position Indicator (PPI) or Tach, generates square wave output pulses to indicate shaft rotation. It is typically fitted with a pair of measuring wheels and used to measure linear movement, such as on a conveyor system. The number of pulses per revolution of the shaft and the output circuit type are selectable by setting configuration switches. For conveyor or web applications, accessories are available for mounting either above or below the conveyor belt/roller.

FEATURES

- Programmable Pulses per revolution
- Programmable Output Circuit
- "Anti-Jitter" circuit
- ESD Protection
- Short Circuit / Reverse Voltage Protected



* Requires surge protection option if cable exceeds 100' / 30m or leaves the building.

DIMENSIONS

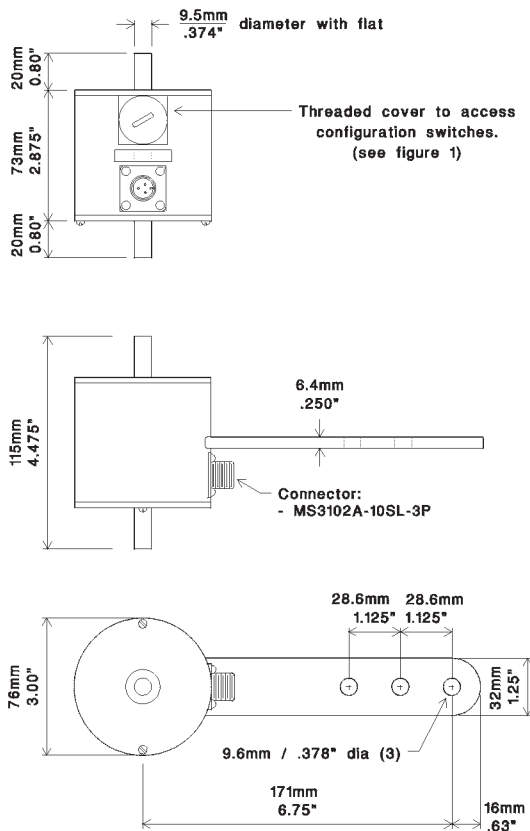

Electrical

Supply Voltage (V_{IN}): (specify when ordering)

Model	Voltage	R-Value*
RH-P144AJ/5	5 ± 5% vdc	1K
RH-P144AJ/8-30	8-30 vdc	3.3K

* See output circuit, figure 2 below

Supply Current: 50ma maximum (no load)

Output Current (I_O): 50ma max source/sink

Output Circuit: Selectable by setting switches 6 to 8 (see figures 1 and 2)

- Current sinking NPN transistor
- NPN open collector ($V_{CC}=30$ vdc maximum)
- Current sourcing PNP transistor
- Combined sourcing/sinking output (push/pull output)

Output Protection:

- Short Circuit
- ESD to 8KV direct and 25KV air

Operating temperature: -25° to +85° C

Maximum operating speed: 3,000 rpm

RoHS Compliant Models: RH-P144AJ/5 RC or RH-P144AJ/8-30 RC

Outputs

Pulses per Revolution: Selectable by setting switches 1 to 5 (see figure 1). Output is "low" when power is initially applied.

Output Waveform: 50/50 squarewave

- **Pulse On-Off Ratio:** 50% ± 10%
- **Pulse Interval Jitter:** ±10%
- **Pulse rise time:** 2 µsec (max)
- **Pulse fall time:** 5 µsec (max)
- **Voltage (high):** $V_{IN}-2.5$ vdc (min)
- **Voltage (low):** 1.5 vdc (max)

(600 rpm, $V_{IN}=24$ vdc, $10ma < I_O < 50ma$, 25°C)

Anti-jitter: The anti-jitter feature increases the pulse output hysteresis to 1/2 of a pulse width, eliminating the effects of mechanical vibration and the possible dither that results in false output pulses. For example, a 10 pulse per revolution output would have 18° hysteresis (i.e. $360° \div 10 \times 1/2$).

SPECIFICATIONS

Electrical Connections

Pin No.	Function	Wire Color
A	Supply Voltage	Red
B	Output	White
C	Common	Black
—	Case Ground	Plain

Connector: MS3102A-10SL-3P (3-pin)

Mating Connector: MS3106A-10SL-3S

Mechanical

Weight: 1.3 lb (600 gm) without accessories

Shaft Loading: Radial: 25 lb. (11.3 kg.) max. Axial: 10 lb. (6.8 kg.) max.

Bearing Life (L_{10}): 70 x 10⁶/RPM = hours

Materials:

- Case: Aluminum, anodized
- Shaft: 303 Stainless steel
- Switch Cover: plastic

Accessories

Cable assemblies, measuring wheels, and mounting hardware are available. Call or see our website.

Configuration Switches

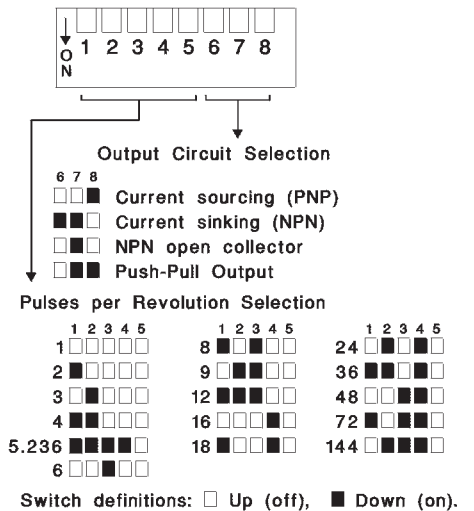

Figure 1 - Configuration Switches

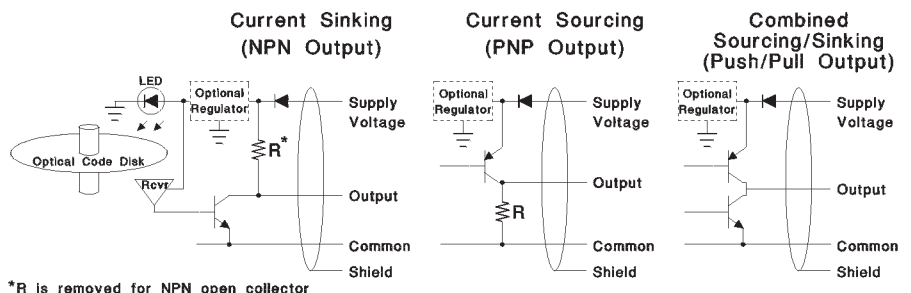

Figure 2 - Output Circuits

OVER 30 YEARS OF MATERIAL HANDLING AND INDUSTRIAL EXPERIENCE

602 E. North Street
Elburn, IL 60119, USA
www.photocraftencoders.com

630-365-7148
Fax: 630-365-7149