

**FEATURES**

- Up to 3/8" or 10mm shaft bore diameter
- DIP switch selectable pulses per revolution
- Pulse output with Anti-Jitter feature
- CE and RoHS compliant available
- ESD and short circuit protection
- 5 vdc and 8 to 30 vdc supply voltages
- 9-pin D-Sub or 4-pin M12 connector
- Non-programmable models available - see HS25

**DIMENSIONS**

(shown with 3/8" shaft bore and 9-pin D-sub connector)

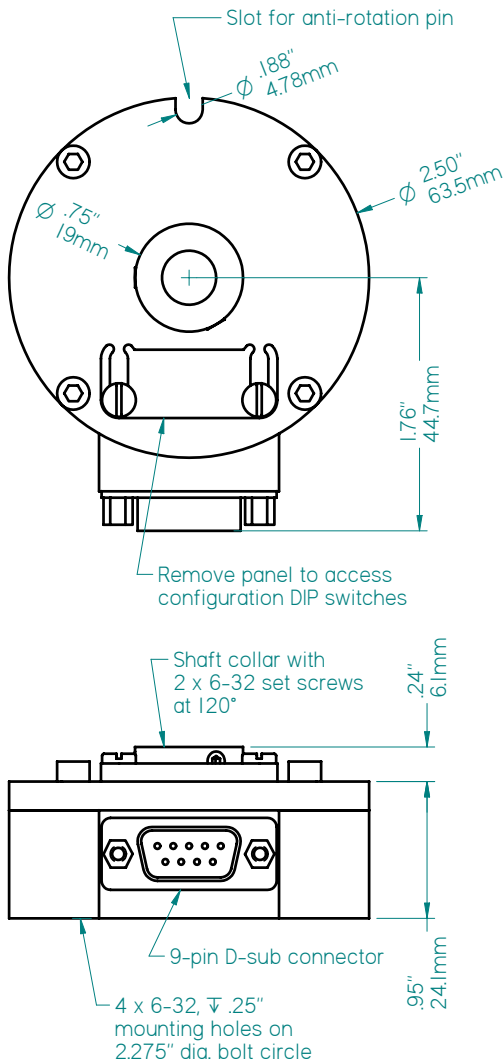

602 E. North Street **630-365-7148**  
 Elburn, IL 60119, USA Fax: 630-365-7149  
[www.photocraftencoders.com](http://www.photocraftencoders.com)

**SPECIFICATIONS**

**Mechanical**

**Shaft Bore:** Any up to 3/8", 10mm diameter  
**Maximum Speed:** 600 rpm  
**Shaft Loading:**  
 — Radial: 5.5 lbs. / 2.5 kg max.  
 — Axial: 2.2 lbs. / 1 kg max.  
*A flexible mounting bracket is recommended.*  
**Bearing Life:** 42 x 1,000,000/rpm = hours  
**Materials:**  
 — Case: Aluminum, anodized  
 — Shaft: 303 Stainless steel  
 — Switch cover: ABS plastic  
**Weight:** 5.5 oz. (156 grams)

**Electrical Connections**

9-pin D-sub Pin No.	4-pin M12 Pin No.	Function	Wire Color
1	3	Common	Black
2	1	+vdc	Red
3	4	Output A	White
4-9	2	not used	-

**Installation Notes**

1. Slide the HS25 onto the shaft and tighten set screws. Be sure to maintain clearance around the entire encoder body.
2. Use the anti-rotation screw, flexible mounting bracket, or other means to prevent the encoder from rotating.
3. Attach the cable leads to the control device (e.g. PLC) ensuring that the power supply meets specifications.
4. Attach the cable to the encoder.

**Accessories**

See our website or contact us for more information about Cables, Flexible Mounting Brackets, and the Anti-Rotation Pin.

**Electrical**

**Supply Voltages:** (specify when ordering)  
 5 ± 5% VDC or 8-30 VDC  
**Current:** 50 mA max (no load)  
**Pulse Rate:** 0 - 30 kHz  
**Operating Temperature:** 0° to 70° C  
**Output Circuit:** (specify when ordering)  
 — Push/Pull (combined sourcing/sinking)  
 — NPN open collector (Vcc=30 vdc max)  
**Output Current:** 50ma max source/sink  
**Output Waveshape:**

Square wave outputs A and B are 50/50 duty cycle nominal. A leads B by 90° for clockwise rotation when viewed from shaft collar end.  
 — Pulse symmetry: 180°±30%  
 — Pulse interval jitter: 30% max  
 — Quadrature: 90°±30% max  
 — Phase jitter: 30% max

**Configuration Switches**

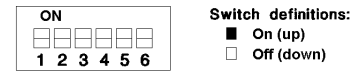

Pulses per Revolution Selection																	
1	2	3	4	5	6	1	2	3	4	5	6	1	2	3	4	5	6
1	□	□	□	□	□	22	□	□	□	□	□	43	□	□	□	□	□
2	□	□	□	□	□	23	□	□	□	□	□	44	□	□	□	□	□
3	□	□	□	□	□	24	□	□	□	□	□	45	□	□	□	□	□
4	□	□	□	□	□	25	□	□	□	□	□	46	□	□	□	□	□
5	□	□	□	□	□	26	□	□	□	□	□	47	□	□	□	□	□
6	□	□	□	□	□	27	□	□	□	□	□	48	□	□	□	□	□
7	□	□	□	□	□	28	□	□	□	□	□	49	□	□	□	□	□
8	□	□	□	□	□	29	□	□	□	□	□	50	□	□	□	□	□
9	□	□	□	□	□	30	□	□	□	□	□	51	□	□	□	□	□
10	□	□	□	□	□	31	□	□	□	□	□	52	□	□	□	□	□
11	□	□	□	□	□	32	□	□	□	□	□	53	□	□	□	□	□
12	□	□	□	□	□	33	□	□	□	□	□	54	□	□	□	□	□
13	□	□	□	□	□	34	□	□	□	□	□	55	□	□	□	□	□
14	□	□	□	□	□	35	□	□	□	□	□	56	□	□	□	□	□
15	□	□	□	□	□	36	□	□	□	□	□	57	□	□	□	□	□
16	□	□	□	□	□	37	□	□	□	□	□	58	□	□	□	□	□
17	□	□	□	□	□	38	□	□	□	□	□	59	□	□	□	□	□
18	□	□	□	□	□	39	□	□	□	□	□	60	□	□	□	□	□
19	□	□	□	□	□	40	□	□	□	□	□	61	□	□	□	□	□
20	□	□	□	□	□	41	□	□	□	□	□	62	□	□	□	□	□
21	□	□	□	□	□	42	□	□	□	□	□	63	□	□	□	□	□
												64	□	□	□	□	□

**MODEL NUMBER**

<b>HS25</b>		<b>P</b>	<b>64AJ</b>				
<b>Model Number</b>	HS25	<b>P</b> = Programmable model	<b>64AJ</b> = name of factory configured program.				
<b>Shaft Bore:</b> A = 5/16", B = 3/8", C = 1/4", .188 = 3/16", M6 = 6mm, M8 = 8mm, M10 = 10mm							
<b>Supply Voltage:</b> 5 = 5vdc, 8-30 = 8 to 30 vdc							
<b>Output Circuit:</b> leave blank for push/pull C = NPN open collector							
<b>Connector:</b> leave blank for 9-pin D-Sub, S3 = 4-pin M12 connector							
<b>Modification Number:</b> optional modification or special feature ID. Call or see our website.							
<b>Accessories:</b> leave blank for no accessories. Call or see our website for more information.							

Example: **HS25B-P64AJ/8-30** - 3/8" shaft bore, programmable model factory configured with the 64AJ program, 8-30 vdc, push/pull output, 9-pin D-Sub connector