

MW-8 and MW-20

Measuring Wheels

DIMENSIONS

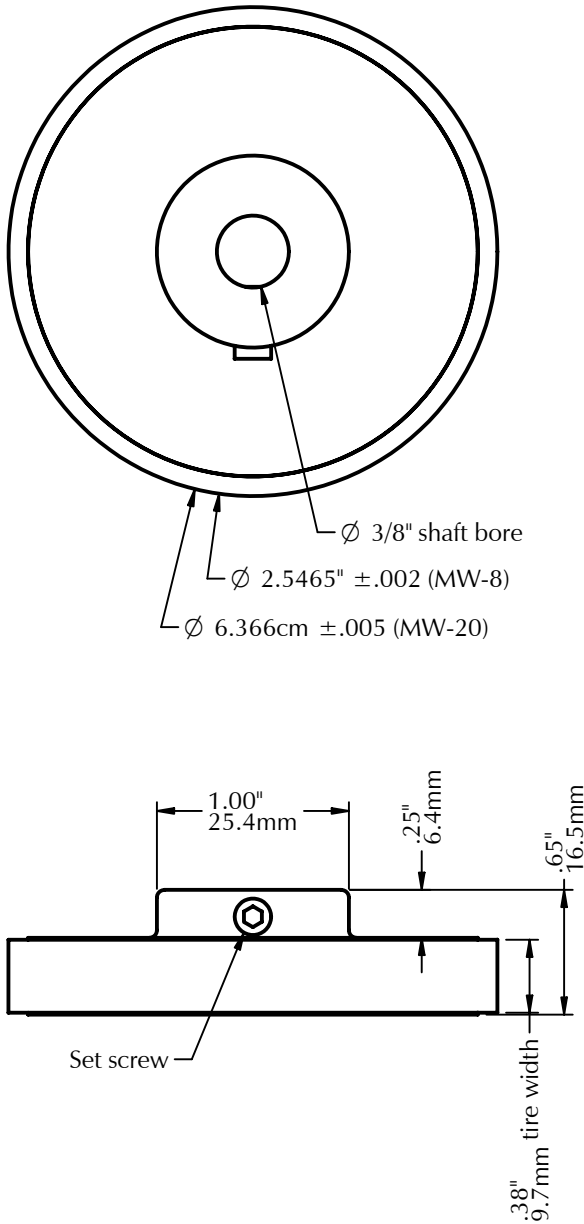

DESCRIPTION

The **MW-8** and **MW-20** measuring wheels provide an accurate way to precisely measure linear movement of a conveyor or web when used with the R22 wheeled encoder. The wheels are aluminum with a urethane tire with a precisely ground tread, and having a high coefficient of friction that resists slipping. They attach to an encoder shaft using a 10-24 set screw.

SPECIFICATIONS

MW-8 dimensions: 8.00" ± .007" circumference
 2.5465" ± .002" diameter

MW-20 dimensions: 20.00cm ± .016cm circumference
 6.3662cm ± .005cm diameter

Shore Hardness of tire: 83A
 Operating Temperature Range: -25° to 65°C, -20° to 150°F
 Urethane is FDA compliant, food grade.

INSTALLATION and MAINTENANCE

Measuring wheels should be installed such that they are perpendicular to and their rotation is directly in line with the moving web or conveyor, or there could be premature wheel tread wear. For the double wheel R22 encoder, use of the Y-1, Y-3, MB-UB1, MB-UB2, MB-UB3, or MB-UB4 mounting adapters allow the R22 encoder to self-align with the moving web. The underbelt adapters apply an upward force that is directly along the centerline of the R22 encoder, minimizing wheel wear. On curved sections of conveyors, we recommend the use of the IW modification with the RH encoder, or use a single wheeled encoder. Special care must be used when installing a single wheel encoder to ensure it is properly aligned.

Maintenance consists of periodically cleaning the wheel tread. In dirty environments this is especially important since dirt accumulation on the wheel will increase its diameter.

MODEL NUMBERS

MW			
Measuring Wheel	Circumference: 8 = 8" (2.5465" dia.), 20 = 20 centimeters (6.3662cm dia.)	Type: leave blank for standard width (there are no other options at this time)	Shaft Size: B = 3/8" (there are no other options at this time)

Examples: **MW-8-B** (8" circumference, 3/8" shaft)
MW-20-B (20cm circumference, 3/8" shaft)



602 E. North Street 630-365-7148
 Elburn, IL 60119, USA Fax: 630-365-7149
www.photocraftencoders.com